

# Multi-User Communication using Chaotic Frequency Modulation

A. R. Volkovskii, S.C.Young, L.S.Tsimring, and N.F.Rulkov

*Abstract*—In this paper we consider the use of the chaotic frequency modulation (CFM) in multi-user communications. In this scheme the base station transmits the reference signal with chaotically varying frequency. All users synchronize their chaotic oscillators to this signal and use it to generate their own information-carrying CFM signal. Using numerical simulations and experiments with electronic circuits we evaluate the BER performance of CFM.

## I. INTRODUCTION

In the last decade there has been a great interest in exploiting chaotic oscillations for spread-spectrum communications [1]. Active research in this area was initiated by Pecora and Carroll [2] who first demonstrated the robust synchronization of one chaotic oscillator by another. Several different schemes implementing communication using chaos, have been proposed in the recent years. Some of them, such as the differential chaos shift keying (DCKS) [3], do not use the phenomenon of chaotic synchronization, and rely on transmitting the chaotic reference signal along with the modulated signal. In other schemes (chaotic masking [4], inverse systems [5], and parameter modulation [6]), synchronization has been used, however, as subsequent research has shown [7], these methods are susceptible to channel distortions and typically yield poor bit error rate (BER) performance. A better BER performance can be achieved when chaos is used to modulate the temporal characteristics of the carrier waveform (such as in the Chaotic Pulse Position Modulation (CPPM) [8]).

In this paper we consider another method in which chaotic oscillator can be used to modulate the temporal characteristics of the carrier, the Chaotic Frequency Modulation (CFM). This method generalized the familiar Frequency Hopping (FH) method which is widely used in modern spread spectrum communications. FH provides an efficient way to realize the processing gain and provide a reliable communication in fading and/or multi-path environment [9], [10]. Typically, the frequency hopping is controlled by a discrete-valued pseudo-random hopping code. The receiver and transmitter must share the same code and maintain precise code synchronization in order to provide stable detection. The information is usually encoded as a frequency with respect to the nominal FH signal. However, discrete frequency hopping may cause sub-optimal system performance because of spectral splatter and transient mismatch between receiver and transmitter. It has been suggested that continuous frequency variations rather

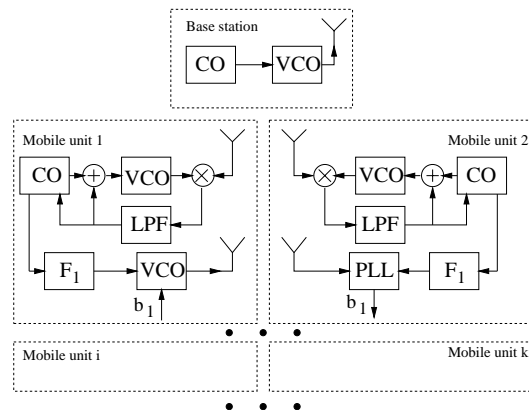

Fig. 1. Block diagram of the multi-user CFM

than discrete hopping may lead to improved system performance [11].

In Ref. [12] we introduced Chaotic Frequency Modulation (CFM) method as a possible way to generate smoothly varying FM carrier signal. The signal from the phase-lock loop was used for synchronization of the chaos generator at the receiver to the chaos generator at the transmitter. We demonstrated the stability of the synchronized state, and moreover, showed the low sensitivity of the proposed method with respect to the interference signals.

In this paper, we describe the application of the CFM method for multi-user communications. We are proposing the following general scheme (Figure 1). The base station (BS) and all receivers have chaos generators (CG) with closely matched parameter values. The base station uses its CG to generate a CFM signal which it broadcasts to all the mobile units. Each receiver receives this signal, and uses it for synchronization of its CG to the BS chaos generator. Once all chaos generators in the cell are synchronized, unit  $i$  can transmit information to unit  $k$  using this chaotic waveform to generate its own information-bearing CFM signal. In order to avoid interference, every transmitter applies its own unique transformation  $F_i$  to the chaotic waveform before generating its CFM carrier. The band in which the mobile units are transmitting the CFM signals should be separated from the “synchronization” band, in which the base station is transmitting the reference CFM signal without interference.

Let us consider first the “synchronization channel”. In the following, we will denote the variables and acronyms corresponding to the base station by subscript  $b$ , and the ones corresponding to the mobile units, by subscript  $u$ . The chaos generator of the base station  $CG_b$  is described

by the following equation

$$\tau \dot{\mathbf{x}}_b = \mathbf{F}(\mathbf{x}_b), \quad (1)$$

where  $\mathbf{x}$  is the vector of state variables of  $CG_b$ ,  $F$  is the nonlinear vector field function, and  $\tau$  denotes the characteristic time constant of the chaos generator. One of the variables of the chaotic system at the base station,  $x_b$ , is used to control the frequency of the  $VCO_b$  producing the reference CFM signal. The equation for the instantaneous phase of the reference CFM signal reads

$$\dot{\varphi}_b \equiv \omega_b = \omega_0(1 + mx_b), \quad (2)$$

where  $\omega_0$  is the “natural” frequency of  $VCO_b$ , and  $m$  is the modulation gain coefficient. The instantaneous phase of the CFM signal generated by the  $VCO_u$ ,  $\varphi_u$ , is described by the similar equation,

$$\dot{\varphi}_u \equiv \omega_u = \omega_0(1 + mx_u), \quad (3)$$

where  $x_u(t)$  is the chaotic signal generated by the  $CG_u$ . The latter is described by the equation

$$\tau \dot{\mathbf{x}}_u = \mathbf{F}(\mathbf{x}_u) + \mathbf{a}v. \quad (4)$$

This chaos generator is controlled by the signal  $v$  from the phase-lock loop (PLL), which is a combination of the phase discriminator and the low-pass filter (see Figure 1). The equation for the PLL can be written as follows,

$$T\dot{v} = \Phi(\varphi_u - \varphi_b) - v, \quad (5)$$

where  $f(x) = \sin(x)$  if the phase detector is implemented using a multiplier and the carriers have a sinusoidal waveform.

We assume that the frequency range of the information transmission does not overlap with the frequency range of the synchronization signal, so the information-bearing signals do not interfere with the synchronization signal. In this case the analysis of the synchronization process between the base station and the mobile units is equivalent to our earlier work [12]. If the characteristic time constant  $\tau$  of the chaos generators is much greater than  $\omega_0^{-1}$ , then there exist a range of parameters  $T, m_b, m_u$ , in which the synchronized solution of Eqs.(1)- (5)

$$\begin{aligned} \mathbf{x}_b &= \mathbf{x}_u, \\ \varphi_u &= \varphi_b, \\ v &= 0, \end{aligned} \quad (6)$$

is stable.

Now let us turn to the information transmission among the mobile units. Once  $CG$ s of the mobile units are synchronized to the chaos generator of the base station, they can be used to generate the CFM signal for information transmission. The phase of the information-bearing signal transmitted by the  $i$ th mobile unit (transmitter) is described by the following equation,

$$\dot{\varphi}_i \equiv \omega_i = \omega_1(1 + m_1 f_i(\mathbf{x}_i) + m_2 b_n^i), \quad i = 1, \dots, N. \quad (7)$$

Here  $N$  is the total number of transmitting mobile units,  $f_i(\mathbf{x})$  is a unique function assigned to the  $i$ -th unit, and  $b_n^i$  is the  $n$ -th bit of its information sequence.

If the information from the  $i$ -th unit is sent to the  $k$ -th unit, the latter must use the same function  $f_i(\mathbf{x})$  to be able to tune in to the signal sent by the  $i$ -th unit. The dynamics of the PLL at the  $k$ -th unit are controlled by the equations

$$\dot{\varphi}_k \equiv \omega_k = \omega_1(1 + m_1 f_i(\mathbf{x}_k) + m_3 v_k), \quad (8)$$

$$T\dot{v}_k = \sum_{i=1, i \neq k}^N \Phi(\varphi_k - \varphi_i) - v_k. \quad (9)$$

If only one  $i$ -th unit is transmitting ( $N = 1$ ), and the channel is noise- and distortion-free, the set of Eqs.(7)-(9) possesses a perfect synchronized solution

$$u_k = m_u^{-1} m_b b_n^i, \quad (10)$$

$$\varphi_k - \varphi_i = \Phi^{-1} u_k, \quad (11)$$

Therefore, the receiver  $k$  can determine the transmitted bit  $b_n$  without errors by the sign of the output of the PLL  $u_k$  integrated over the bit duration.

In a multi-user system, other units besides  $i$ , are transmitting the information-bearing signal in the same frequency range near  $\omega_1$ . This causes an interference signal in the PLL of the  $k$ -th receiver, which leads to certain bit errors.

## II. PERFORMANCE EVALUATION

In our numerical simulations and experiments with electronic circuits we used the following simple chaotic oscillator (model B from [13]),

$$\begin{aligned} \dot{x} &= yz \\ \dot{y} &= x - y \\ \dot{z} &= 1 - xy \end{aligned} \quad (12)$$

$$(13)$$

We implemented this system in the electronic circuit shown in Figure 2. This circuit uses one quadruple operational amplifier TL084N and two multipliers AD633. The chaotic attractor of system (12) is shown in Figure 3.

In electronic experiments, we evaluated the system sketched in Figure 1, with one base station and two communication units. VCOs and PLLs of the base station and the mobile units were implemented using standard 74HC4046 chip. The nominal frequency  $f_0$  of the VCOs was 1.8 MHz. The characteristic time constant of the chaos generators was 56  $\mu$ msec. In these experiments the base station and the mobile units were connected by a wire. As a function  $f(\mathbf{x})$  controlling the VCOs of the mobile units, we used the second variable of the chaotic generator (12),  $y$  (see Figure 2).

The quality of the synchronization between the base station and the mobile units can be illustrated by the plot  $x_u$  vs.  $x_b$  (Figure 4,a).

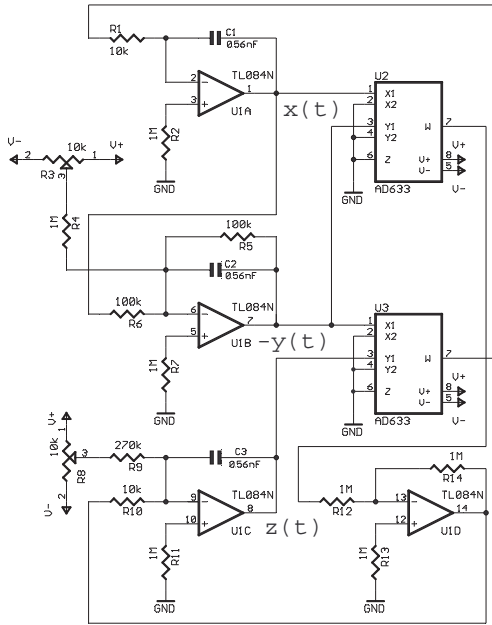

Fig. 2. Circuit diagram of the chaotic oscillator used in the experiments

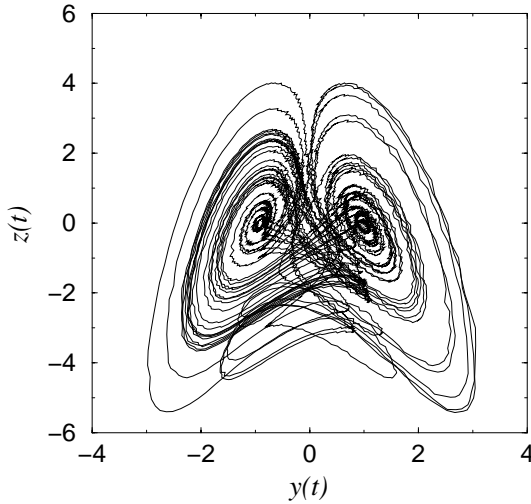

Fig. 3. Chaotic attractor of system (12) obtained experimentally in a circuit shown in Figure 2.

The power spectra of the chaotic signal (“baseband”) and the CFM signal are shown in Figure 5.

We transmitted binary information (pseudo-random sequence of bits) between two mobile units by increasing the instantaneous frequency of the  $VCO_u$  by 30 kHz with respect to  $f_u$  for bit “1” transmission, and decreasing it by 30 kHz for bit “0”. The output signal from the phase lock loop of the receiving mobile unit is shown in Figure 6. It was integrated over the bit duration for detecting the information bit.

To evaluate the system performance, we added white Gaussian noise to the transmission channel, and calculated the bit-error rate as a function of the normalized signal-

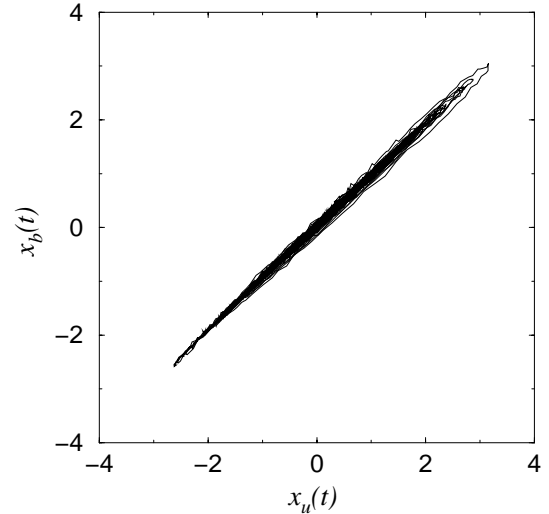

Fig. 4. Synchronization between the chaos generators of the base station and a mobile unit in electronic circuit

to-noise ratio (more precisely, ratio of the energy per bit to the spectral density of noise  $E_b/N_0$ ). The obtained performance curve can be compared with the standard non-coherent FSK performance [14] (see Figure 7). As one can see, the performance is slightly worse than FSK (by about 1 dB) for  $BER > 10^{-3}$ , however it flattens out at lower BER. The reason for this behavior is the instability of the phase lock loop which is caused by occasional events of PLL de-synchronization. These events occur even if the chaotic oscillators at the receiver and transmitter are perfectly synchronized (see Figure 7, open circles), however at a lower level of BER.

The performance of the system described in the previous section for multiple pairs of mobile units was studied in the numerical simulations. We chose the parameters of the simulation to satisfy the stability criteria of the synchronization in a single-user system, namely,  $m_u = 0.05$ ,  $m_1 = 2$ ,  $T = 20$ ,  $\tau = 50$ . Here  $T$  and  $\tau$  were set in reference to  $\omega_1$ , which was set to 1. The synchronization plot  $x_u$  vs.  $x_b$  is presented in Figure 4,b. In order to generate statistically independent signals using a single “source” signal  $x(t)$  from the base station, transmitters used time-delayed versions of the chaotic signal  $x(t - \Delta T_i)$  with different time delays  $\Delta T_i$  corresponding to different users. Figure 8 shows the bit-error rate as a function of the number of users for bit lengths  $20\tau$  and  $40\tau$ .

### III. CONCLUSIONS

In this paper we extended our analysis of the Chaotic Frequency Modulation method [12] for a multi-user communication. Mobile units are synchronized by the base station which generates chaotically-modulated FM signal. All mobile units are synchronized to that signal by using the PLL output as a feedback control signal. The information is transmitted between the mobile units using frequency shift keying with respect to the chaotic FM signals. Although all units share the same frequency range for the

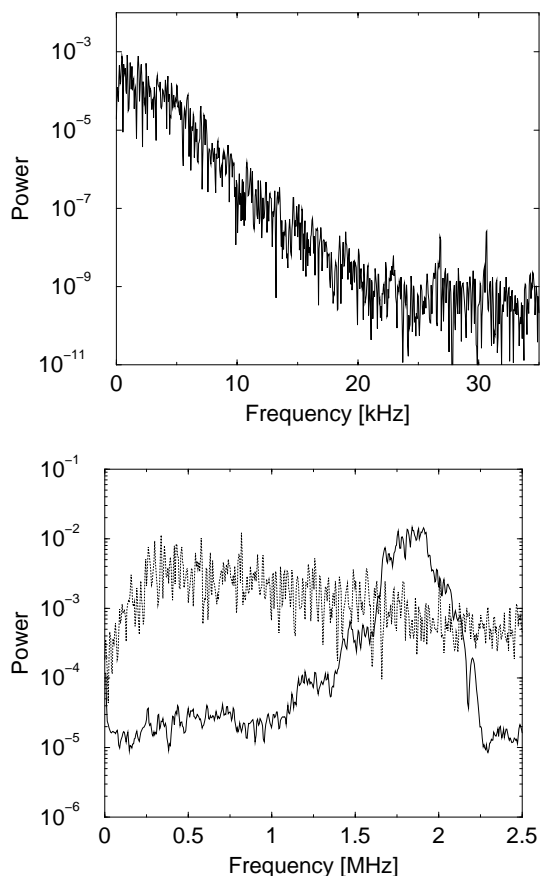

Fig. 5. Power spectra of the baseband chaotic signal (top) and the CFM signal (bottom). In the bottom plot, the power spectrum of the channel noise is also shown by the dotted line.

information transmission, every unit transmits on its own unique CFM carrier which is derived from the synchronizing signal broadcasted by the base unit. We studied the performance of this system in electronic experiment with one pair of mobile units, and in numerical simulations with multiple pairs of units. It was demonstrated that the proposed method offers a good selectivity, reliable multi-user performance, and therefore allows an efficient use of the spectral bandwidth.

Authors are indebted to H. Abarbanel, L. Larson, and M. Sushchik for numerous discussions on the subject. This work was supported by the U.S. Army Research Office under MURI grant DAAG55-98-1-0269 and by the U.S. Department of Energy under grant DOE/DE-FG03-95R14516.

#### REFERENCES

- [1] M.P.Kennedy and G.Kolumban (Eds.) Noncoherent chaotic communications (special issue), *IEEE Trans. Circuit. Syst. I*, vol.47(12), 2000.
- [2] L. M. Pecora and T. L. Carroll. Synchronization in chaotic systems. *Phys. Rev. Lett.*, vol.64, pp.821–824, 1990.
- [3] M.P.Kennedy, G.Kolumban, G.Kis, and Z.Jákó. “Performance evaluation of FM-DPSK modulation in multipath environments”, *IEEE Trans. Circuit Syst. I*, vol.47, pp.1702–1711, 2000.
- [4] L.Kocarev, K.S.Halle, L.O.Chua, and U.Parlitz, “Experimental demonstration of secure communication via chaotic synchronization”, *Int. J. Bifurc. Chaos*, vol. 2, no.3, pp. 709–713, 1992;

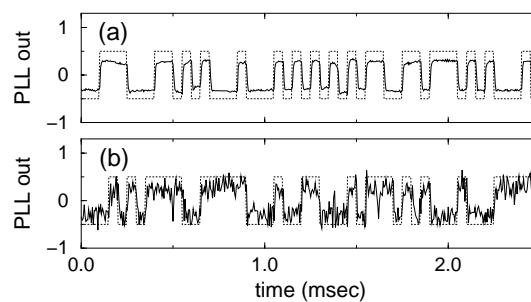

Fig. 6. The output voltage  $v$  from the PLL of the mobile unit for two different values of the noise level: (a)  $E_b/N_0 = 20dB$ , (b)  $E_b/N_0 = 7dB$ . Dotted lines indicate the original bit sequence

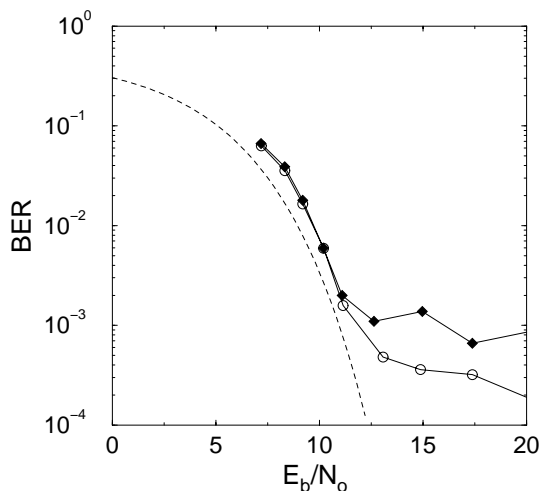

Fig. 7. Bit-error rate in the single-user CFM transmission as a function of the normalized signal-to noise ratio  $E_b/N_0$  (solid squares), same for perfectly synchronized chaos oscillators at the transmitter and the receiver (open circles), and ideal non-coherent FSK (dashed line)

- K.M.Cuomo and A.V.Oppenheim. “Circuit implementation of synchronized chaos with applications to communications”, *Phys. Rev. Lett.*, vol. 74, pp.5028–5031, 1993; T.L.Carroll and L.M.Pecora. “Cascading synchronized chaotic systems”, *Physica D*, vol. 67, pp. 126–140, 1993.
- [5] A.R.Volkovskii and N.F.Rulkov, “Synchronous chaotic response of a nonlinear oscillating system as a principle for the detection of the information component of chaos”, *Tech. Phys. Lett.*, vol. 19, no.2, pp.97–99, 1993; U. Feldmann, M.Hasler, and W.Schwarz, “Communication by chaotic signals: The inverse system approach”, *Int. J. Circuit Theory Appl.*, v.24, pp. 551–579, 1995; L.Kocarev and U.Parlitz, “General approach for chaotic synchronization with applications to communication”, *Phys. Rev. Lett.*, vol. 74, pp.5028–5031, 1995;
- [6] L.Kocarev and U.Parlitz, “Multichannel communication using autotynchronization”, *Int. J. Bifurc. Chaos*, vol. 6, no. 3, pp.581–588, 1996.
- [7] C.-C. Chen and K. Yao, “Stochastic-calculus-based numerical evaluation and performance analysis of chaotic communication systems”, *IEEE Trans. Circ. Systems I*, vol.47 no.12, pp. 1663–1672, 2000.
- [8] M.M. Sushchik et al., “Chaotic pulse position modulation: a robust method of communicating with chaos”, *IEEE Comm. Lett.*, vol.4, no.4, pp. 128–130, 2000.
- [9] R. A. Scholtz, “The origins of Spread Spectrum Communications”, *IEEE Trans. Commun.*, **COM-30**, pp. 822–854 (1982).
- [10] R. L. Pickholtz, D. L. Schilling and L. B. Milstein, “Theory of spread Spectrum Communications – A Tutorial”, *IEEE Trans.*

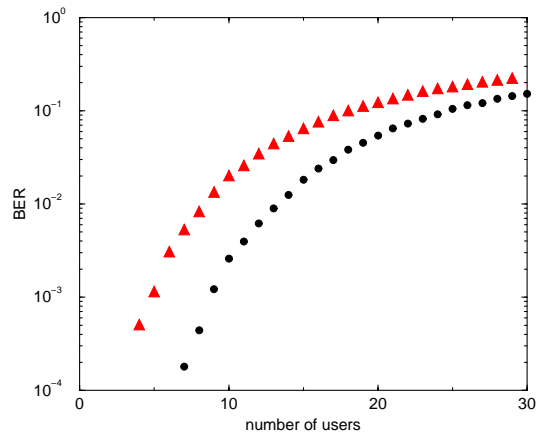

Fig. 8. Bit-error rate in the multi-user CFM transmission as a function of the number of users for two values of bit length:  $20\tau$  (triangles) and  $40\tau$  (circles).

- Commun.*, **COM-30**, pp. 855–884, (1982).
- [11] N. M. Filiol, C. Plett, T. Riley, and M. A. Copeland, “An Interpolated Frequency-Hopping Spread-Spectrum Transceiver”, *IEEE Trans. Circuits Syst.*, **45**, pp. 3–12, (1998).
- [12] A.R.Volkovskii and L.S.Tsimring, “Synchronization an communication using chaotic frequency modulation”, *Int. J. Circ. Theor. Appl.*, vol.27, pp.569-576, 1999.
- [13] J.C.Sprott, “Some simple chaotic flows”, *Physical Review E*, vol. 50(2), pp.R647-650, 1994.
- [14] M.K.Simon, J.K.Omura, R. A. Scholtz, and B.K.Levitt, “Spread Spectrum Communication Handbook”, McGraw-Hill, New York, 1994.